

Multicore Performance and Tools

Part 1: Topology, affinity, clock speed



Tools for Node-level Performance Engineering

- **Node Information**

*/proc/cpuinfo, numactl, hwloc, **likwid-topology**, likwid-powermeter*

- **Affinity control** and data placement

*OpenMP and MPI runtime environments, hwloc, numactl, **likwid-pin***

- **Runtime Profiling**

Compilers, gprof, perf, HPC Toolkit, Intel Amplifier, ...

- **Performance Analysis**

*Intel VTune, **likwid-perfctr**, PAPI-based tools, HPC Toolkit, Linux perf*

- **Microbenchmarking**

*STREAM, **likwid-bench**, Imbench, uarch-bench*

LIKWID performance tools

LIKWID tool suite:

Like
I
Knew
What
I'm
Doing

 <https://youtu.be/6uF11HPq-88>

Open source tool collection
(developed at RRZE):



<https://github.com/RRZE-HPC/likwid>

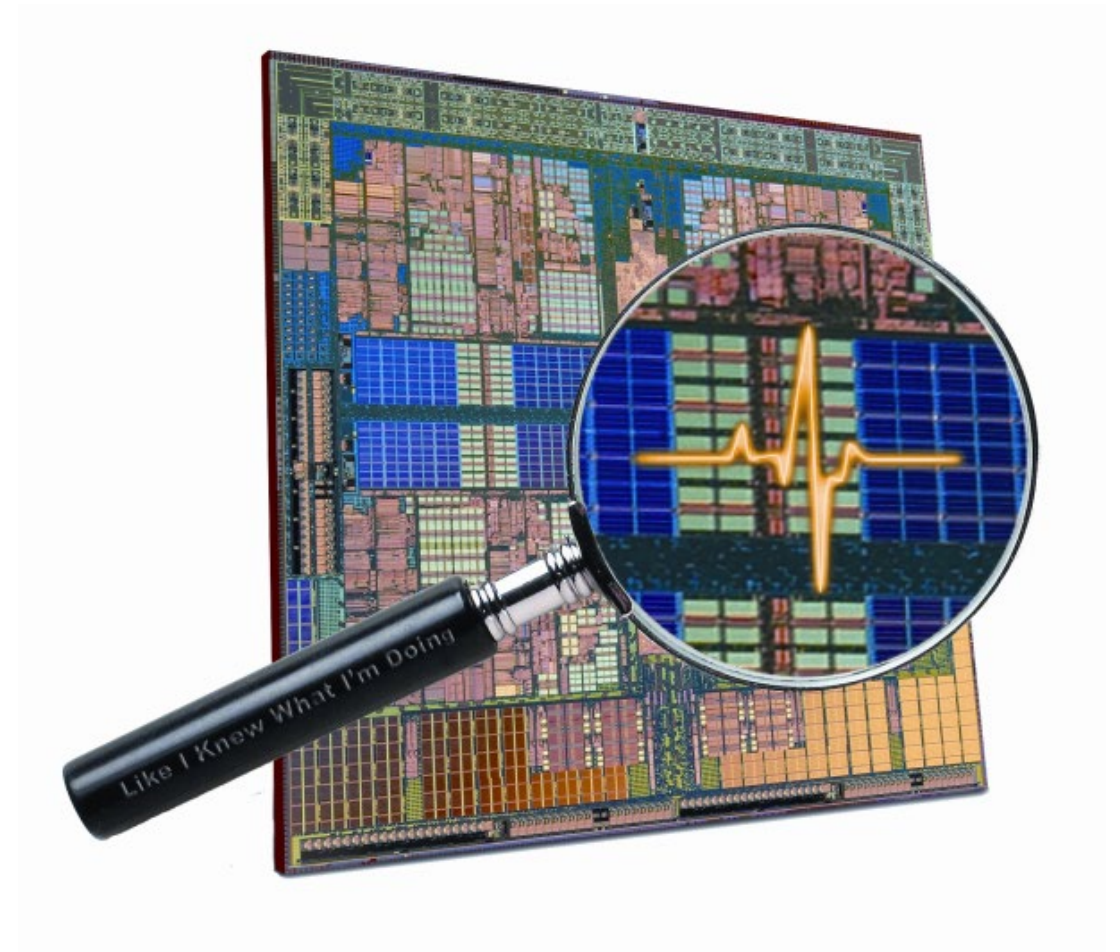

J. Treibig, G. Hager, G. Wellein: *LIKWID: A lightweight performance-oriented tool suite for x86 multicore environments*. PSTI2010, Sep 13-16, 2010, San Diego, CA. DOI: [10.1109/ICPPW.2010.38](https://doi.org/10.1109/ICPPW.2010.38)

LIKWID Tool Suite

- Command line tools for Linux:
 - easy to install
 - works with standard Linux kernel
 - simple and clear to use
 - supports most X86 CPUs

(also ARMv8, POWER9 and Nvidia GPUs)



- Current tools:

likwid-topology - Print thread and cache topology
likwid-pin - Pin threaded application without touching code
likwid-perfctr - Measure performance counters
likwid-powermeter - Measure energy consumption
likwid-bench - Microbenchmarking tool and environment

... some more

Reporting topology

likwid-topology

 <https://youtu.be/mxMWjNe73SI>



Output of `likwid-topology`

on one node of Intel Icelake SP

```
$ likwid-topology
```

```
-----  
CPU name:   Intel(R) Xeon(R) Platinum 8360Y CPU @ 2.40GHz  
CPU type:   Intel Icelake SP processor  
CPU stepping: 6  
*****
```

Hardware Thread Topology

```
*****  
Sockets:           2  
Cores per socket:  36  
Threads per core:  1  
-----
```

HWThread	Thread	Core	Die	Socket	Available
0	0	0	0	0	*
1	0	1	0	0	*
[...]					
70	0	70	0	1	*
71	0	71	0	1	*

```
-----  
Socket 0:           ( 0 1 2 3 4 5 6 7 8 9 10 11 12 13 14 15 ... 23 24 25 26 27 28 29 30 31 32 33 34 35 )  
Socket 1:           ( 36 37 38 39 40 41 42 43 44 45 46 47 48 ... 59 60 61 62 63 64 65 66 67 68 69 70 71 )  
-----
```

Cache Topology

```
*****  
Level:              1  
Size:                48 kB  
Cache groups:       ( 0 ) ( 1 ) ( 2 ) ( 3 ) ( 4 ) ( 5 ) ... ( 64 ) ( 65 ) ( 66 ) ( 67 ) ( 68 ) ( 69 ) ( 70 ) ( 71 )  
-----
```

```
Level:              2  
Size:                1.25 MB  
Cache groups:       ( 0 ) ( 1 ) ( 2 ) ( 3 ) ( 4 ) ( 5 ) ... ( 64 ) ( 65 ) ( 66 ) ( 67 ) ( 68 ) ( 69 ) ( 70 ) ( 71 )  
-----
```

```
Level:              3  
Size:                54 MB  
Cache groups:       ( 0 1 2 3 4 5 6 7 8 9 10 11 12 13 14 15 ... 23 24 25 26 27 28 29 30 31 32 33 34 35 )  
                   ( 36 37 38 39 40 41 42 43 44 45 46 47 48 ... 59 60 61 62 63 64 65 66 67 68 69 70 71 )  
-----
```

**All OS hardware
thread IDs**

Output of `likwid-topology` continued

```
*****
NUMA Topology
*****
NUMA domains:                4
-----
Domain:                      0
Processors:                  ( 0 1 2 3 4 5 6 7 8 9 10 11 12 13 14 15 16 17 )
Distances:                   10 11 20 20
Free memory:                 119059 MB
Total memory:                128553 MB
-----
Domain:                      1
Processors:                  ( 18 19 20 21 22 23 24 25 26 27 28 29 30 31 32 33 34 35 )
Distances:                   11 10 20 20
Free memory:                 128196 MB
Total memory:                129020 MB
-----
Domain:                      2
Processors:                  ( 36 37 38 39 40 41 42 43 44 45 46 47 48 49 50 51 52 53 )
Distances:                   20 20 10 11
Free memory:                 128033 MB
Total memory:                128978 MB
-----
Domain:                      3
Processors:                  ( 54 55 56 57 58 59 60 61 62 63 64 65 66 67 68 69 70 71 )
Distances:                   20 20 11 10
Free memory:                 128719 MB
Total memory:                129017 MB
-----
```

Output similar to
`numactl --hardware`

Sockets: 2
Threads per core: 1

Sub-NUMA clustering (SNC)
enabled, SMT disabled!

Output of `likwid-topology -g`

**Intel Haswell EP, 14 cores per socket
Cluster on Die (CoD) mode and SMT enabled!**

Graphical Topology

Socket 0:

0	28	1	29	2	30	3	31	4	32	5	33	6	34	7	35	8	36	9	37	10	38	11	39	12	40	13	41	
32kB	32kB	32kB	32kB	32kB	32kB	32kB	32kB	32kB	32kB	32kB	32kB	32kB	32kB	32kB	32kB	32kB	32kB	32kB	32kB	32kB	32kB	32kB	32kB	32kB	32kB	32kB	32kB	32kB
256kB	256kB	256kB	256kB	256kB	256kB	256kB	256kB	256kB	256kB	256kB	256kB	256kB	256kB	256kB	256kB	256kB	256kB	256kB	256kB	256kB	256kB	256kB	256kB	256kB	256kB	256kB	256kB	256kB
17MB														17MB														

Socket 1:

14	42	15	43	16	44	17	45	18	46	19	47	20	48	21	49	22	50	23	51	24	52	25	53	26	54	27	55	
32kB	32kB	32kB	32kB	32kB	32kB	32kB	32kB	32kB	32kB	32kB	32kB	32kB	32kB	32kB	32kB	32kB	32kB	32kB	32kB	32kB	32kB	32kB	32kB	32kB	32kB	32kB	32kB	32kB
256kB	256kB	256kB	256kB	256kB	256kB	256kB	256kB	256kB	256kB	256kB	256kB	256kB	256kB	256kB	256kB	256kB	256kB	256kB	256kB	256kB	256kB	256kB	256kB	256kB	256kB	256kB	256kB	256kB
17MB														17MB														

Enforcing thread/process affinity under the Linux OS

likwid-pin

 <https://youtu.be/PSJKNQaqwB0>



DAXPY test on A64FX

Anarchy vs. thread pinning

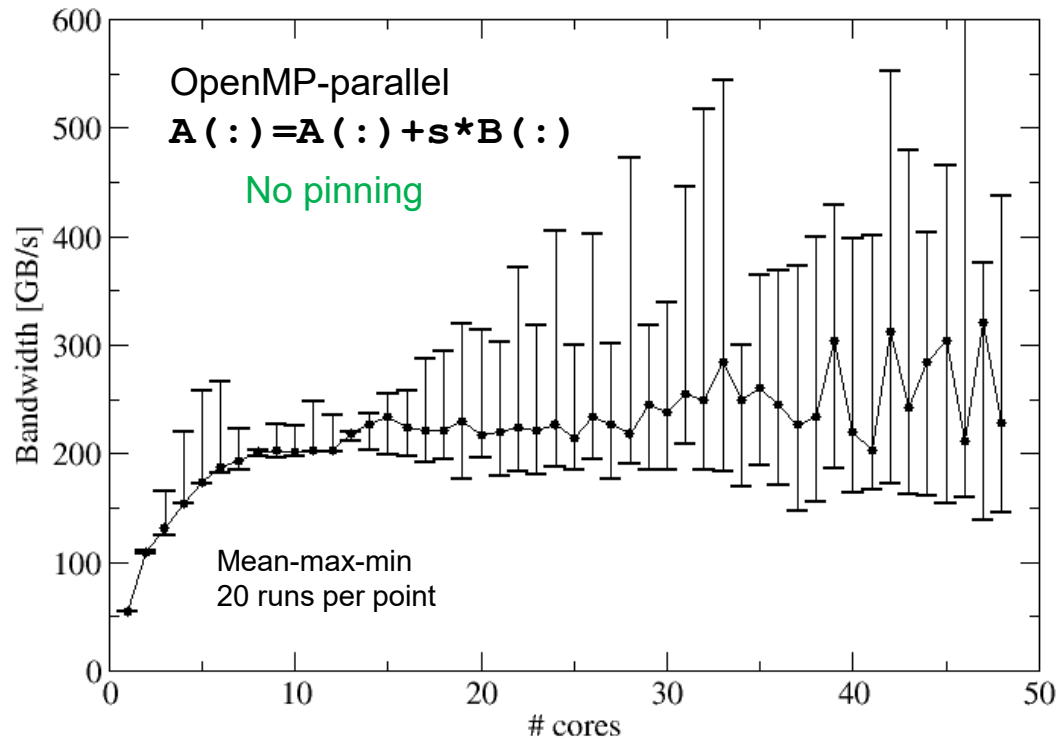

There are several reasons for caring about affinity:

- Eliminating performance variation
- Making use of architectural features
- Avoiding resource contention

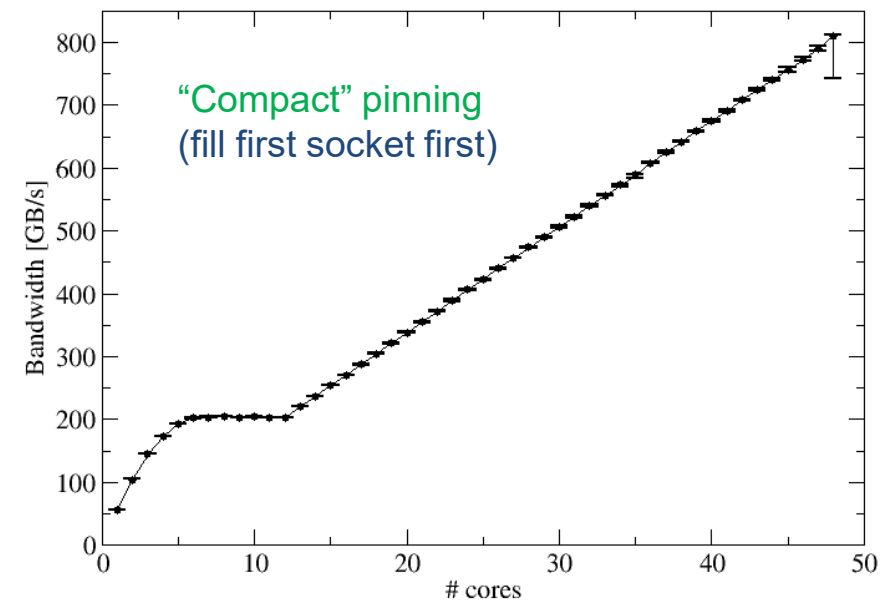
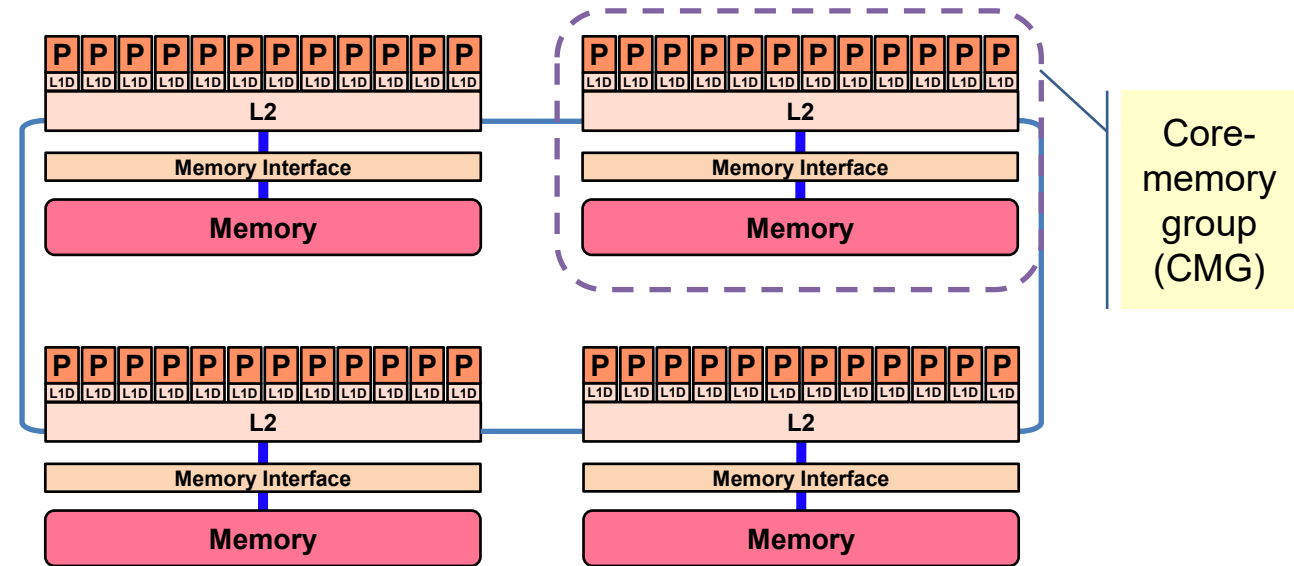

Vector triad on 2x 18-core node: Compact vs. spread pinning

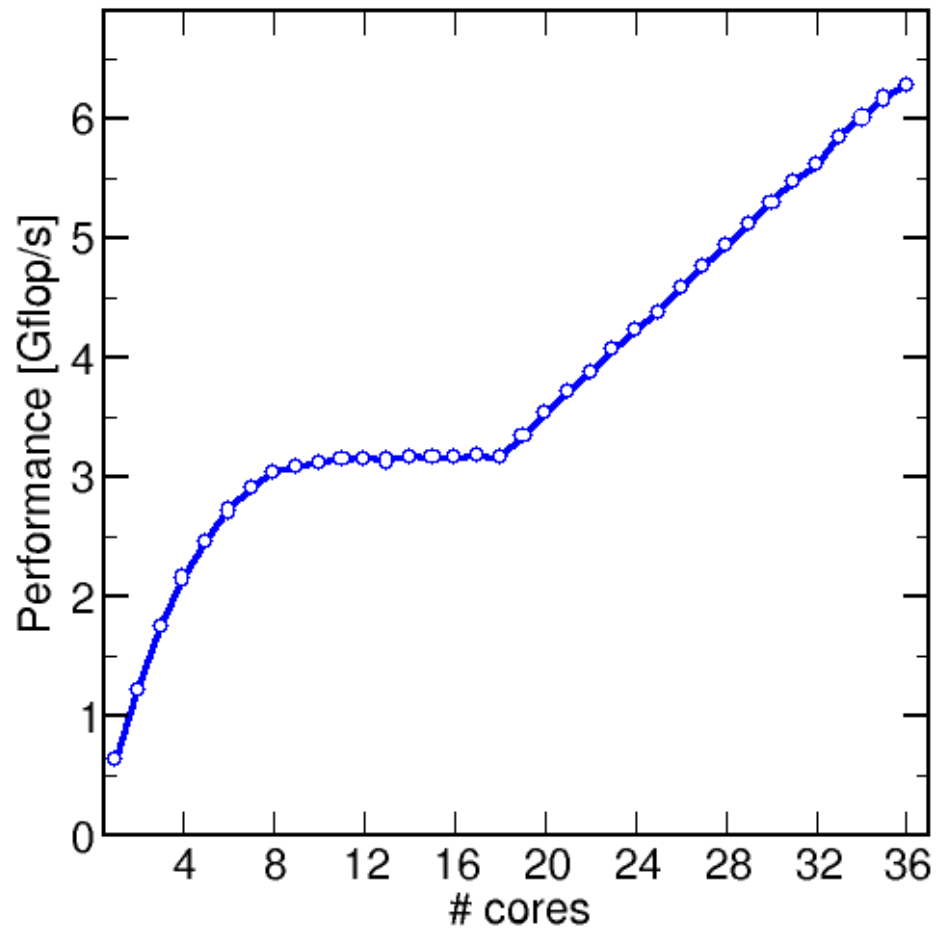

Filling cores from left to right
("compact" pinning)

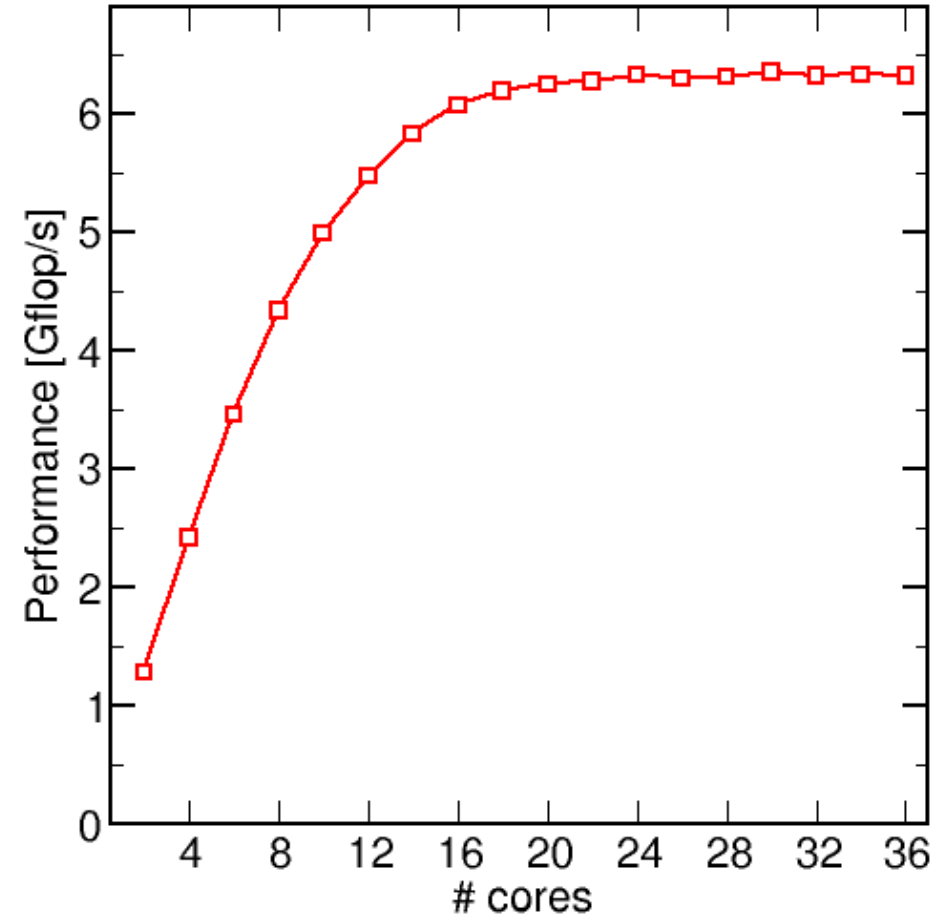

Filling both sockets simultaneously
("scattered" or "spread" pinning)

Interlude: Why the weird scaling behavior?

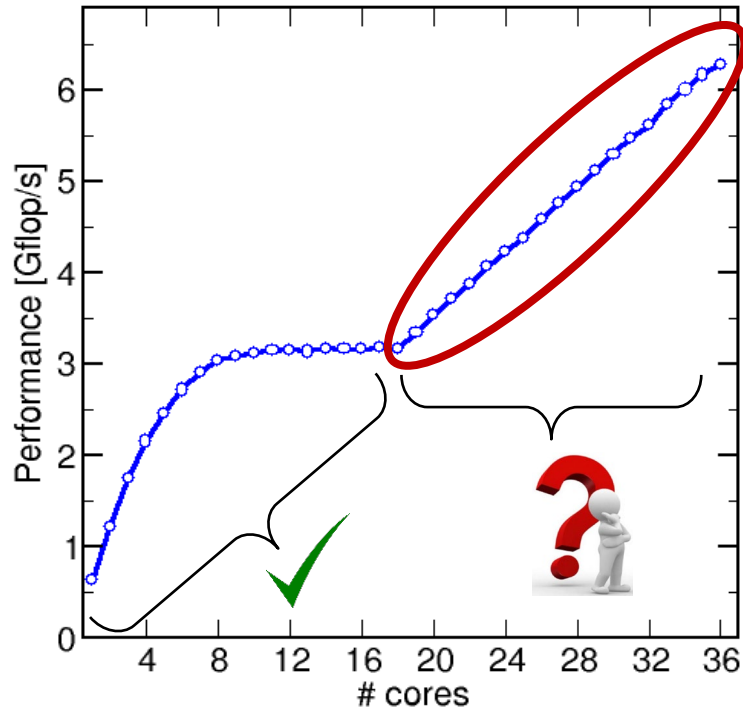

```
!$omp parallel do schedule(static)
do i = 1,N
    a(i) = b(i) + s * c(i)
!$omp end parallel do
```

implicit barrier

- Every thread has the same workload
- Performance of left socket is saturated
- Barrier enforces waiting of “speeders” at sync point
- Average performance of each “right” core == average performance of each “left” core → linear scaling

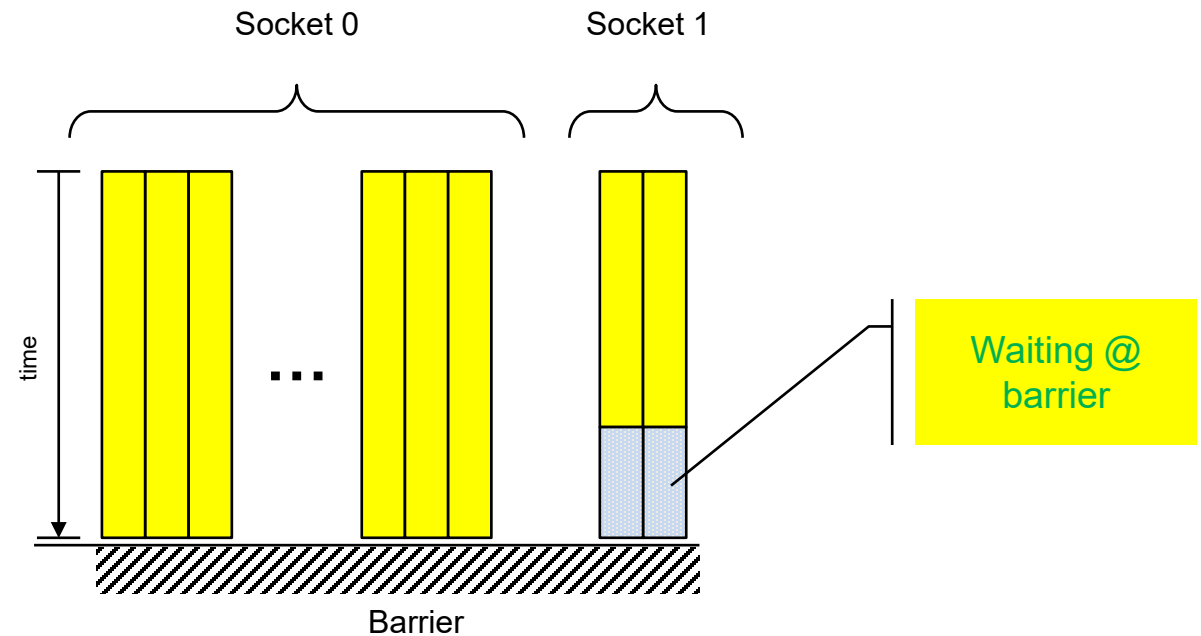

More thread/process affinity (“pinning”) options

- Highly OS-dependent system calls but available on all systems
 - Linux: `sched_setaffinity()`
 - Windows: `SetThreadAffinityMask()`
 - OS X: `thread_policy_set()`
- Hwloc project (<http://www.open-mpi.de/projects/hwloc/>)
- Support for “semi-automatic” pinning
 - All modern compilers with OpenMP support
OpenMP 4.0 (`OMP_PLACES`, `OMP_PROC_BIND`)
 - CPUset reduction utils: `taskset` or `numactl`
 - Job scheduler like **SLURM**
- Affinity awareness in MPI libraries (OpenMPI, Intel MPI, ...)

Overview `likwid-pin`

- Pins processes and threads to specific cores **without touching code**
- Directly supports pthreads, gcc OpenMP, Intel OpenMP
- Based on combination of wrapper tool together with overloaded pthread library
→ **binary must be dynamically linked!**
- Supports **logical core numbering** within topological entities (thread domains)

- Simple usage with **physical (kernel) core IDs**:

```
$ likwid-pin -c 0-3,4,6 ./myApp parameters
```

```
$ OMP_NUM_THREADS=4 likwid-pin -c 0-9 ./myApp params
```

- Simple usage with **logical core IDs** (“thread groups”):

```
$ likwid-pin -c S0:0-7 ./myApp params
```

```
$ likwid-pin -c C1:0-2 ./myApp params
```

LIKWID terminology: Thread group syntax

- The OS numbers all hardware threads (called “processors” in the OS) on a node
- The numbering is enforced at boot time by the BIOS
- LIKWID introduces **thread domains** consisting of HW threads sharing a topological entity (e.g. socket or shared cache)
- A **thread domain** is defined by a single **character + index**

- Example for likwid-pin:

```
$ likwid-pin -c S0:0-3 ./a.out
```

Physical HW threads first!

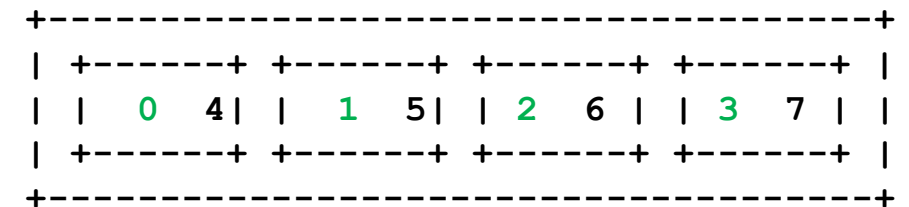

- Thread group expressions may be chained with @:

```
$ likwid-pin -c S0:0-2@S1:0-2 ./a.out
```

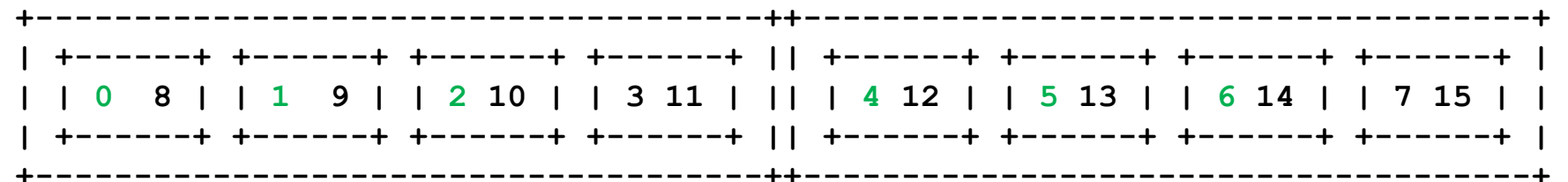

Available thread domains/unit prefixes (as of LIKWID 5.3)

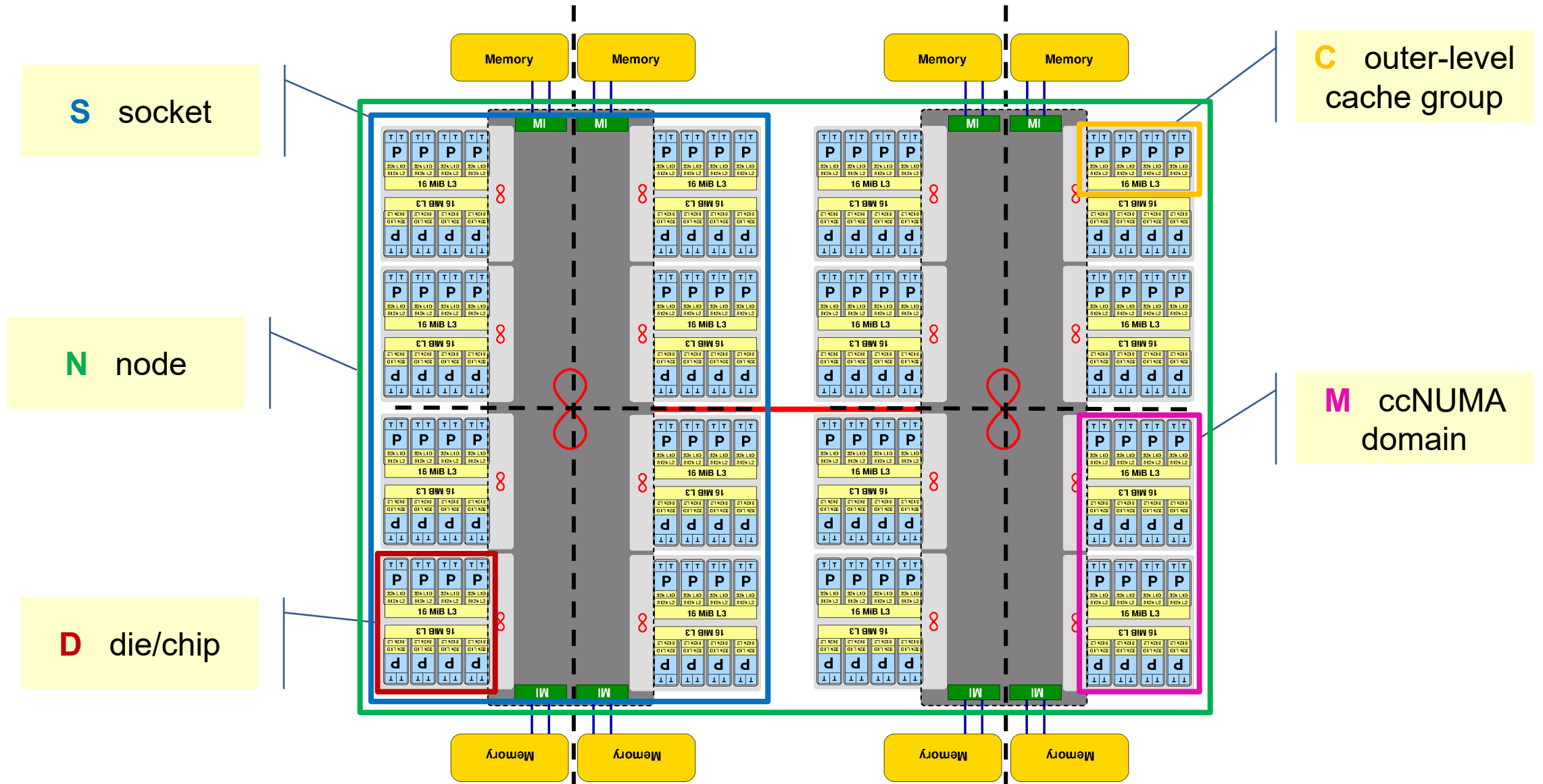

Advanced options for pinning: Expressions

- Expressions are more powerful in situations where the pin mask would be very long or clumsy

Compact pinning (counting through hardware threads):

```
$ likwid-pin -c E:<thread domain>:\
  <number of threads>\
  [:<chunk size>:<stride>] ...
$ likwid-pin -c E:N:4
```

“Compact” placement!

```
+-----+
| +-----+ +-----+ +-----+ +-----+ |
| | 0 4 | | 1 5 | | 2 6 | | 3 7 | |
| +-----+ +-----+ +-----+ +-----+ |
+-----+
```

Scattered pinning across all domains of the designated type:

```
$ likwid-pin -c <domaintype>:scatter
```

- Examples:

```
$ likwid-pin -c E:N:8:1:2 ...
```

```
+-----+
| +-----+ +-----+ +-----+ +-----+ || +-----+ +-----+ +-----+ +-----+ | | | | | | | | | | | | | | | | |
| | 0 8 | | 1 9 | | 2 10 | | 3 11 | || | 4 12 | | 5 13 | | 6 14 | | 7 15 | |
| +-----+ +-----+ +-----+ +-----+ || +-----+ +-----+ +-----+ +-----+ |
+-----+
```

- Scatter across all NUMA domains:

```
$ likwid-pin -c M:scatter
```

Example: `likwid-pin` with Intel OpenMP

Running the STREAM benchmark with `likwid-pin`:

```
$ likwid-pin -c S0:0-3 ./stream
```

```
-----  
Double precision appears to have 16 digits of accuracy  
Assuming 8 bytes per DOUBLE PRECISION word  
-----
```

```
Array size = 20000000  
Offset = 32  
The total memory requirement is 457 MB  
You are running each test 10 times  
--  
The *best* time for each test is used  
*EXCLUDING* the first and last iterations  
[pthread wrapper]  
[pthread wrapper] MAIN -> 0  
[pthread wrapper] PIN_MASK: 0->1 1->2 2->3  
[pthread wrapper] SKIP MASK: 0x0  
threadid 47308666070912 -> core 1 - OK  
threadid 47308670273536 -> core 2 - OK  
threadid 47308674476160 -> core 3 - OK
```

Main PID always
pinned

Pin all spawned
threads in turn

[... rest of STREAM output omitted ...]

OMP_PLACES and Thread Affinity

optional

Processor: smallest entity able to run a thread or task (hardware thread)

Place: one or more processors → thread pinning is done place by place

Free migration of the threads on a place between the processors of that place.

abstract name

OMP_PLACES	Place ==
threads	Hardware thread (hyper-thread)
cores	All HW threads of a single core
sockets	All HW threads of a socket
abstract_name (num_places)	Restrict # of places available

Or use explicit numbering, e.g. 8 places, each consisting of 4 processors:

- `OMP_PLACES="{0,1,2,3},{4,5,6,7},{8,9,10,11}, ... {28,29,30,31}"`
- `OMP_PLACES="{0:4},{4:4},{8:4}, ... {28:4}"`
- `OMP_PLACES="{0:4}:8:4"`

<lower-bound>:<number of entries>[:<stride>]

Caveat: Actual behavior is implementation defined!

OMP_PROC_BIND variable / proc_bind() clause

optional

Determines how places are used for pinning:

OMP_PROC_BIND	Meaning
FALSE	Affinity disabled
TRUE	Affinity enabled, implementation defined strategy
CLOSE	Threads bind to consecutive places
SPREAD	Threads are evenly scattered among places
MASTER	Threads bind to the same place as the master thread that was running before the parallel region was entered

If there are more threads than places, consecutive threads are put into individual places (“balanced”)

Some simple OMP_PLACES examples

optional

Intel Xeon w/ SMT, 2x10 cores, 1 thread per physical core, fill 1 socket

```
OMP_NUM_THREADS=10  
OMP_PLACES=cores  
OMP_PROC_BIND=close
```

Always prefer abstract places
instead of HW thread IDs!

Intel Xeon Phi with 72 cores,
32 cores to be used, 2 threads per physical core

```
OMP_NUM_THREADS=64  
OMP_PLACES=cores(32)  
OMP_PROC_BIND=close      # spread will also do
```

Intel Xeon, 2 sockets, 4 threads per socket (no binding within socket!)

```
OMP_NUM_THREADS=8  
OMP_PLACES=sockets  
OMP_PROC_BIND=close      # spread will also do
```

Intel Xeon, 2 sockets, 4 threads per socket, binding to cores

```
OMP_NUM_THREADS=8  
OMP_PLACES=cores  
OMP_PROC_BIND=spread
```

MPI startup and hybrid pinning: `likwid-mpirun`

- How do you manage affinity with MPI or hybrid MPI/threading?
- In the long run a unified standard is needed
- Till then, `likwid-mpirun` provides a portable/flexible solution
- The examples here are for Intel MPI/OpenMP programs, but are also applicable to other threading models

Pure MPI:

```
$ likwid-mpirun -np 16 -nperdomain S:2 ./a.out
```

Hybrid:

```
$ likwid-mpirun -np 16 -pin S0:0,1_S1:0,1 ./a.out
```

```
$ likwid-mpirun -np 16 -nperdomain S:1 -t 2 ./a.out
```

likwid-mpirun 1 MPI process per socket

```
$ likwid-mpirun -np 4 -pin S0:0-5_S1:0-5 ./a.out
```

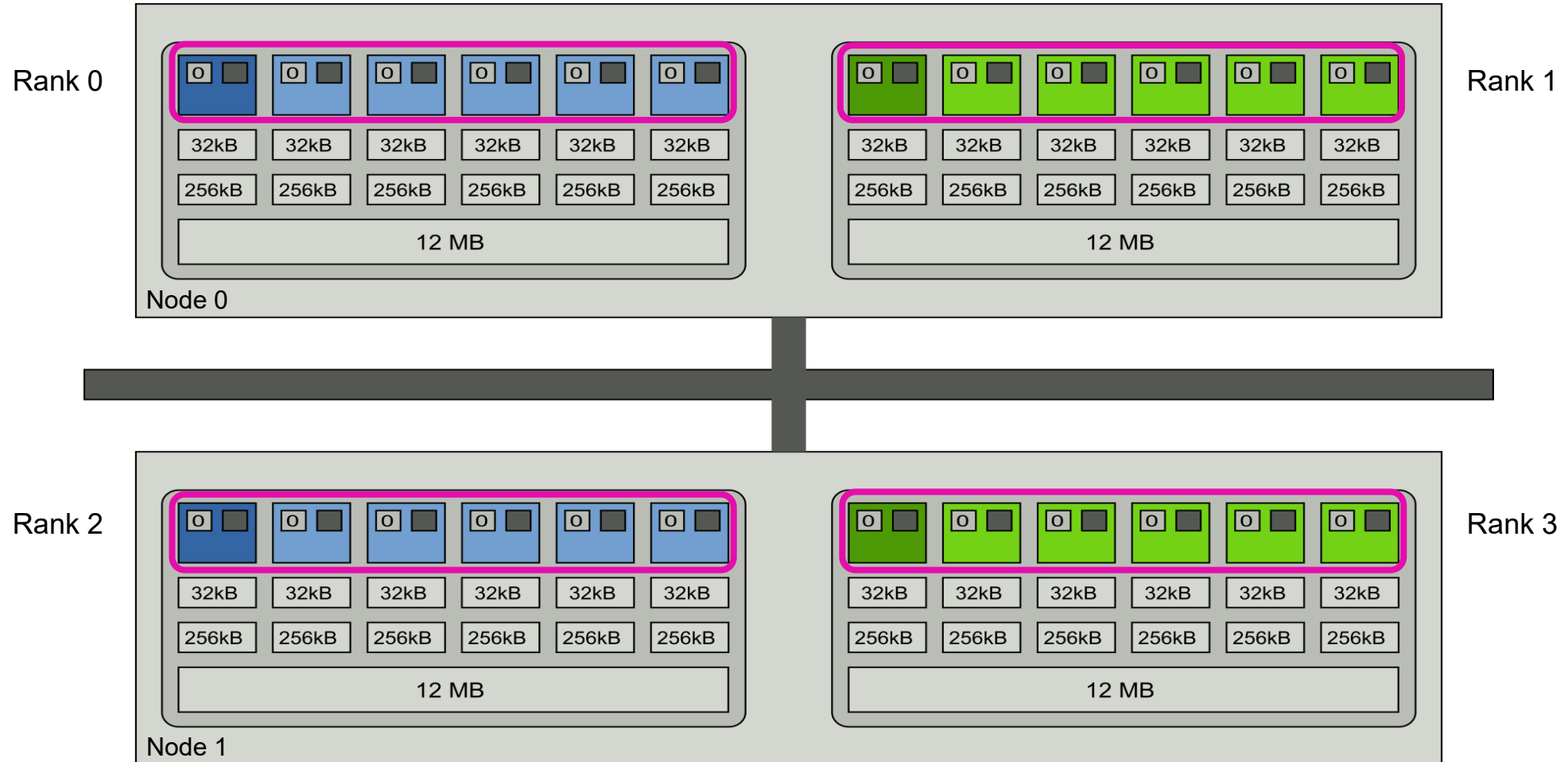

Intel MPI+compiler:

```
OMP_NUM_THREADS=6 mpirun -ppn 2 -np 4 \  
-env I_MPI_PIN_DOMAIN socket -env KMP_AFFINITY scatter ./a.out
```

Clock speed under the Linux OS

Turbo steps and likwid-powermeter

likwid-setFrequencies



Which clock speed steps are there?

Uses the Intel RAPL interface (Sandy Bridge++)

```
$ likwid-powermeter -i
```

```
-----  
CPU name:      Intel(R) Xeon(R) CPU E5-2695 v3 @ 2.30GHz  
CPU type:      Intel Xeon Haswell EN/EP/EX processor  
CPU clock:     2.30 GHz  
-----
```

```
Base clock:    2300.00 MHz
```

```
Minimal clock: 1200.00 MHz
```

```
Turbo Boost Steps:
```

```
C0 3300.00 MHz
```

```
C1 3300.00 MHz
```

```
C2 3100.00 MHz
```

```
C3 3000.00 MHz
```

```
C4 2900.00 MHz
```

```
[...]
```

```
C13 2800.00 MHz  
-----
```

Note: AVX code on HSW+ may execute even slower than base freq.

```
Info for RAPL domain PKG:
```

```
Thermal Spec Power: 120 Watt
```

```
Minimum Power: 70 Watt
```

```
Maximum Power: 120 Watt
```

```
Maximum Time Window: 46848 micro sec
```

```
Info for RAPL domain DRAM:
```

```
Thermal Spec Power: 21.5 Watt
```

```
Minimum Power: 5.75 Watt
```

```
Maximum Power: 21.5 Watt
```

```
Maximum Time Window: 44896 micro sec
```

likwid-powermeter can also measure energy consumption, but **likwid-perfctr** can do it better (see later)

Setting the clock frequency

- The “Turbo Mode” feature makes reliable benchmarking harder
 - CPU can change clock speed at its own discretion
- Clock speed reduction may save a lot of energy
- So how do we set the clock speed?
 - LIKWID to the rescue!

```
$ likwid-setFrequencies -l
```

```
Available frequencies:
```

```
1.2 1.3 1.4 1.5 1.6 1.7 1.8 1.9 2 2.1 2.2 2.3
```

```
$ likwid-setFrequencies -p
```

```
Current CPU frequencies:
```

```
CPU 0: governor performance min/cur/max 2.3/2.301/2.301 GHz Turbo 1
```

```
CPU 1: governor performance min/cur/max 2.3/2.301/2.301 GHz Turbo 1
```

```
CPU 2: governor performance min/cur/max 2.3/2.301/2.301 GHz Turbo 1
```

```
CPU 3: governor performance min/cur/max 2.3/2.301/2.301 GHz Turbo 1
```

```
[...]
```

```
$ likwid-setFrequencies -f 2.0 # min=max=2.0
```

```
[...]
```

```
$ likwid-setFrequencies -turbo 0 # turbo off
```



Turbo mode

Uncore clock frequency

optional

Starting with Intel Haswell, the **Uncore** (L3, memory controller, UPI) sits in its own clock domain

```
$ likwid-setFrequencies -p
[...]
```

CPU 68:	governor	performance	min/cur/max	2.3/2.301/2.301	GHz	Turbo	1
CPU 69:	governor	performance	min/cur/max	2.3/2.301/2.301	GHz	Turbo	1
CPU 70:	governor	performance	min/cur/max	2.3/2.301/2.301	GHz	Turbo	1
CPU 71:	governor	performance	min/cur/max	2.3/2.301/2.301	GHz	Turbo	1

Current Uncore frequencies:

Socket 0: min/max 1.2/3.0 GHz

Socket 1: min/max 1.2/3.0 GHz

```
$ likwid-setFrequencies --umin 2.3 --umax 2.3
```

Uncore has considerable impact on power consumption

J. Hofmann et al.: *An analysis of core- and chip-level architectural features in four generations of Intel server processors*. Proc. ISC High Performance 2017. DOI: [10.1007/978-3-319-58667-0_16](https://doi.org/10.1007/978-3-319-58667-0_16).

J. Hofmann et al.: *On the accuracy and usefulness of analytic energy models for contemporary multicore processors*. Proc. ISC High Performance 2018. DOI: [10.1007/978-3-319-92040-5_2](https://doi.org/10.1007/978-3-319-92040-5_2)